

OPTION 4 - 11m
 CHAIN LENGTH: 24600mm
 NUMBER OF PITCHES: 41
 MAKE-UP SECTION
 REQUIRED: 2150mm
 Min TIME TAKEN TO
 COMPLETE LAP: 1min 15 secs

SECTIONS REQ:
 1490 (Motor)
 2x Tensioning units
 1x 800mm
 1x 600mm
 1x 1631mm
 1x 1180mm
 1x 650mm
 1x 1271mm
 2x 2285mm
 1x 2674mm
 4x 90deg Bends

1x 2150mm Make up piece
 to be manufactured.

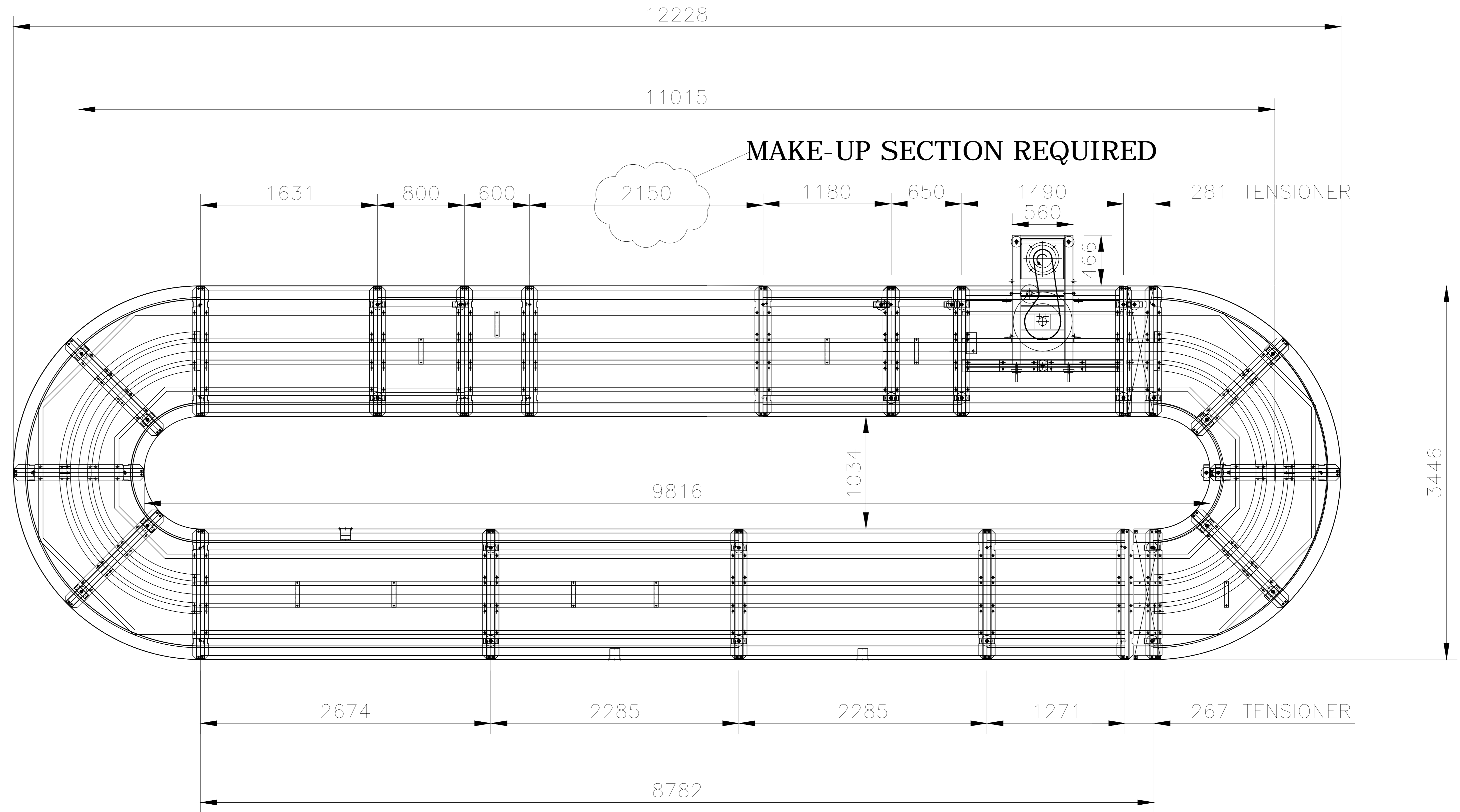

MOTOR DETAILS
 7.5kw 415v 3 Phase 50hz
 VARIABLE SPEED
 MAX SPEED: 0.33m/s

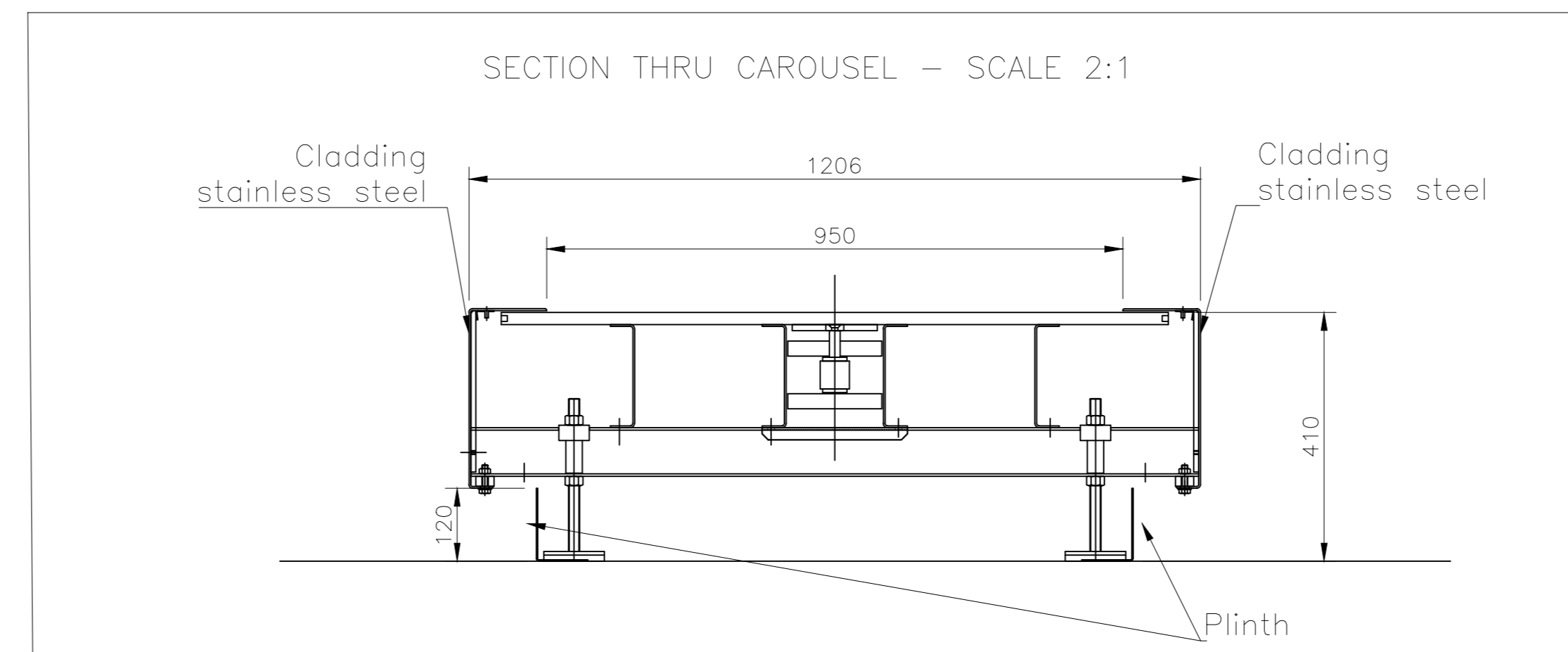

CANNING CONVEYOR Co. LTD.
 Sandy Lane Industrial Estate, Workop, Notts. S80 1TN.
 Telephone: Workop (01909) 486166
 Telex: 547398
 Fax: (01909) 500638

CLIENT CANNING CAROUSEL SYSTEM
 TITLE
 Option 4 - 11m

REV	DATE	DMN	DESCRIPTION

THIS DRAWING IS CONFIDENTIAL AND IS THE PROPERTY OF CANNING CONVEYOR Co. LTD. AND MUST NOT BE REPRODUCED EITHER WHOLLY OR PARTLY WITHOUT THEIR WRITTEN PERMISSION. ALL RIGHTS IN RESPECT OF PATENTS, DESIGN, AND COPYRIGHTS ARE RESERVED.		REMOVE ALL BURRS AND SHARP EDGES STAMP, ENGRAVE OR ETCH WHERE INDICATED THUS (WHERE POSSIBLE 10mm HIGH TEXT) PART No. / MANUFACTURERS CODE, DATE OF MANUFACTURE	DO NOT SCALE IF IN DOUBT ASK ALL DIMENSIONS ARE IN MILLIMETRES UNLESS OTHERWISE STATED	ASSOCIATED DRAWINGS	PROJECTION ~	APPROVED	CHECKED	DRAWN SF	A1	DRG. N°	REV 0
UNLESS OTHERWISE STATED THE FOLLOWING BRITISH STANDARDS TO BE WORKED TO -- DRAWING OFFICE PRACTICE B.S. 308 WELDING SYMBOLS B.S. 499			TOLERANCES TO BE AS BELOW UNLESS OTHERWISE STATED			DATE	DATE	DATE 21/07/16	SCALE 1:25		
MACHINING		FABRICATION PLATE & STRUCTURAL WORK									
UP TO 100 ±0.15		UP TO 300 ±0.40									
100 TO 300 ±0.40		300 TO 1000 ±0.80									
300 TO 1000 ±0.80		1000 & ABOVE ±1.60									